

# ETE-CNY Chapter N-Scale Module Spec

Compiled by Tom Lynch and Peter Verheyen

The ETE-CNY Chapter module spec is based on the Bend-Track specification with several minor modifications, specifically in the area of benchwork and heights. The full Bend-Track module manual can be found at [http://home.alltel.net/ah50902/benchwork\\_manual.htm](http://home.alltel.net/ah50902/benchwork_manual.htm).

## Benchwork:

Benchwork will be Sievers 24" wide with 40" legs or equivalent. Modules can be any length.

See <http://www.sieversbenchwork.com/images/pdfs/sieversthreesections.pdf> for list of pre-fab Sievers modules.

## Module Surface:

Surface will be 1.5" x 24" pink foam insulation board laid on top of Sievers Benchwork.

## Module Height:

Height from floor to upper surface of module 41.5"

## Track:

Track to be Code 80 mounted to cork roadbed or equivalent. Peco and Atlas both make unballasted Code 80 track. **Track centers to be 8.5" and 10" from CENTER of module.**

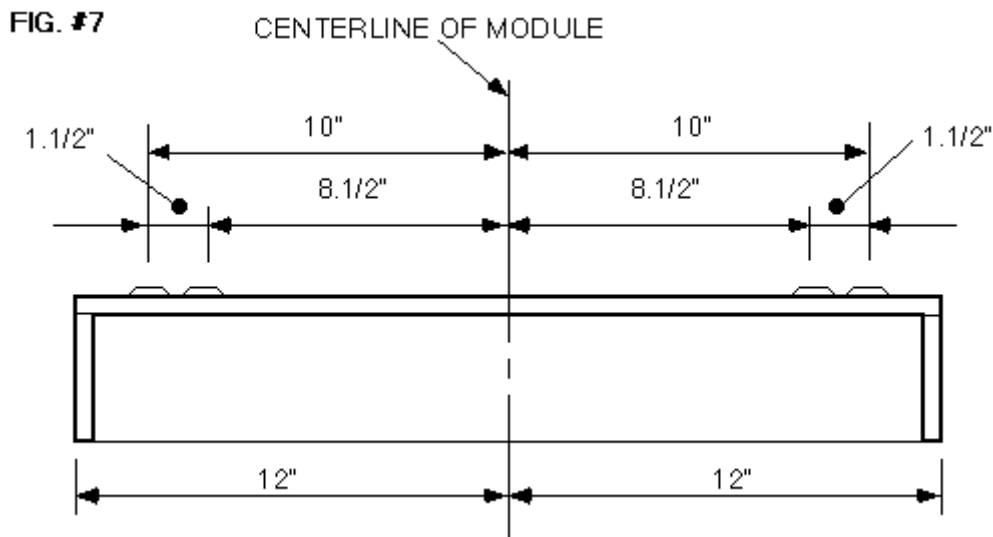

**Tracks need to stop 2 7/16" from the ends of the modules.** This will allow modules to be joined with a 5" Atlas straight section. Any sidings branching off from the main line must be electrically isolated and under their own power control. Any crossovers or connections between the mainlines must also be electrically isolated or gapped.

Anyone not using standard un-ballasted Code 80 track is responsible for making sure that their module will mate with those of others, including building in transitions.

**Catenary:**

There are currently no plans to add catenary to the modules but anyone building modules with tunnels/overpasses should make sure that these are at least 4cm above the top of the track profile to ensure clearance.

**Electrical:**

Electrical wiring to be according to Bend-track specification. No smaller than 18 gauge for mainline power and 16 gauge “white” power line are recommended. Wire should be lamp cord or speaker wire (2 clearly distinct wires, either by color or texture).

Since the modules are double sided, you will have six cords running across the underside of the module. For the feeder wires, use 22 to 24 gauge solid core or speaker wire to tap power from the orange/blue mainline cords to the rails. See FIG #10a. Bend Track also uses the same method for observing the polarity of both mainline and white line cords.

The ribbed/colored wire is connected to the front rail of each mainline and to the colored connector at the end of each bus. Feeder wires from the track to the mainline cords, using speaker wire where one strand is usually colored and matching that to the front rail will simplify wiring.

**Connectors:**

Each bus will be connected to other modules using Anderson PP30 30 Amp Powerpole connectors at each end of the module. These can be obtained from Powerwerx at <<http://www.powerwerx.com/>>. Appropriate colored Powerpole housings will be used as shown below.

Wire	Powerpole Shell Colors	Minimum gauge
Mainline 1	Orange or Red/Black	18 Gauge
Mainline 2	Blue/Black	18 Gauge
Centerline	White/Black	16 Gauge

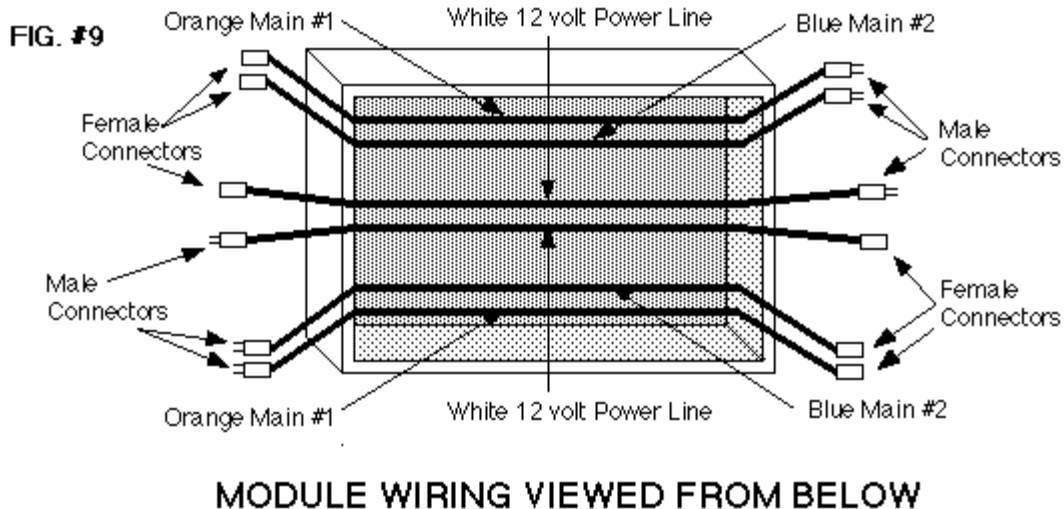

### Position of Wires and Plugs:

The orange/blue cables should approximately follow under the appropriate mainlines, much the same as they do on any N-Trak module. Since the Bend Track module is like having two N-Trak modules which are connected back to back, you will have six wires hanging down on each end of the module instead of N-Trak's 4 wires. Refer to FIG. #10b.

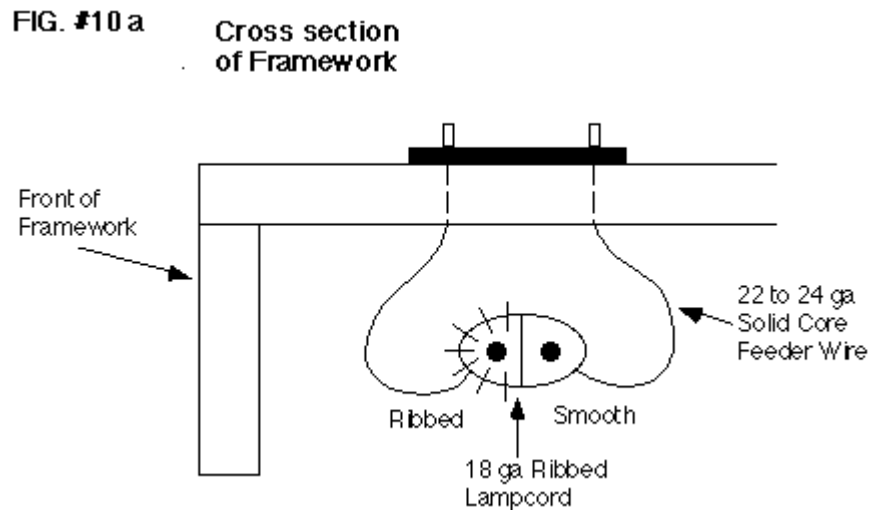

**NOTE:** Where lampcord is ribbed/smooth, speakerwire is generally colored (copper wire or colored stripe). Ribbing/coloration should match up. Feeder wires from the track to the mainline cords, using speaker wire where one strand is usually colored and matching that to the front rail will simplify wiring.

**NOTE:** The front rail should be soldered to colored Powerpole connector. Repeat this process for all mainline connector plugs.

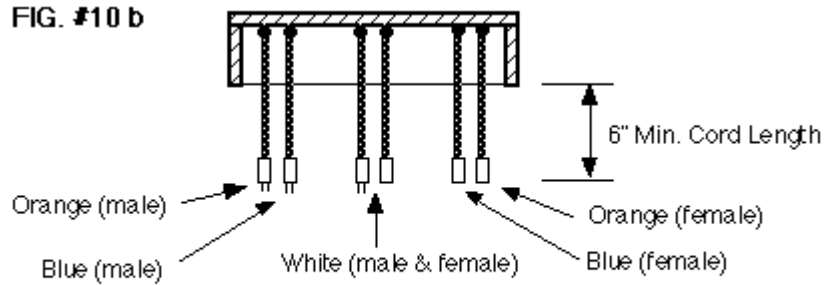

### WIRING POSITION VIEWED FROM END

If possible, at the ends of the module, the orange/blue cords should remain close to the outside edges under the appropriate mains. The white cords should remain close to the center. This will keep them in line when the modules are clamped together and keep the white 12 volt lines away from the mainlines to reduce the chance of 12 volts getting plugged into a mainline. Be sure to leave at least 6" of cord below the bench work on both ends. This will allow an adequate amount of cord to plug into the next module.

### Train Control:

Currently not specified. Layout initially to be run in analog mode. Blocks and signal requirements have also not been specified

### Scenery:

Edges of modules, including the edges of the foam module surface to be painted flat black.

Each module owner is free to design and scenic their modules as they see fit. Only considerations are that scenery at modules be finished so that there will be a smooth transition to the next module. A scene divider can be used, height not to exceed 14".

**For some degree of continuity between modules, please refer to the ETE module spec at <<http://www.ete.org/modspecs2.htm#SCENERY>> that states:**

*Therefore, we have specified Woodland Scenics products as the basis of scenery on the Bay Area modules. We use a layer of light brown paint and an undercoating. While this is still wet, sprinkle a layer of Woodland Scenics # T50 earth blend. Then on top of that, sprinkle # T49 green blend. This gives a very satisfying green European look to the module, because most of Europe is very green. Of course don't limit yourselves to this, as there are rocks, mountains, streams, ponds etc to also be modeled. The basic unified look however is very striking, and the Bay Area chapter has won the "contest" at numerous GATS based on audience comments.]*

Module owners are encouraged to select a theme or scene to model. Adding contours and other features adds interest as well. Remember, this is your opportunity to show your modeling skills and develop new ones. Please, no undecorated table-tops like the ones which appear at train

shows repeatedly. We want to showcase our funny looking trains and our modeling skills to the public. Remember, it doesn't have to be fancy to be effective.

Activities we can engage in as a group are building models and scenic elements such as trees. Larry Herring has offered a 20% discount off the list price (except for Walthers sale items) to members.

**Skirting:**

Modules sides (including foam) should be painted flat black. We may wish to add black skirting to hide legs... This will likely need to be fire-resistant.

**Notes:**

All diagrams for electrical wiring taken from Bend Track Module Spec.

Any and all comments to Tom Lynch, [tommyl@twcny.rr.com](mailto:tommyl@twcny.rr.com), or Peter Verheyen, [verheyen@philobiblon.com](mailto:verheyen@philobiblon.com).